

Study on Natural Convection in a Rectangular Enclosure With a Heating Source

Kang-Youl Bae, Hyo-Min Jeong, Han-Shik Chung*

School of Mechanical & Aerospace Engineering, Institute of Marine Industry, Gyeongsang National University, Gyeongnam 650-160, Korea

The natural convective heat transfer in a rectangular enclosure with a heating source has been studied by experiment and numerical analysis. The governing equations were solved by a finite volume method, a SIMPLE algorithm was adopted to solve a pressure term. The parameters for the numerical study are positions and surface temperatures of a heating source i.e., $Y/H = 0.25, 0.5, 0.75$ and $11^\circ\text{C} \leq \Delta T \leq 59^\circ\text{C}$. The results of isotherms and velocity vectors have been represented, and the numerical results showed a good agreement with experimental values. Based on the numerical results, the mean Nusselt number of the rectangular enclosure wall could be expressed as a function of Grashof number.

Key Words: Heating source, Low Reynolds Number, Turbulence Model, Nusselt Number, Grashof Number

Nomenclature

a : Grid space regulation coefficient
 g : Gravity acceleration [m/s^2]
 Gr : Grashof number $\left(Gr = \frac{g\beta(T_h - T_c)H^3}{\nu^2} \right)$
 H : Vertical wall length [m]
 K : Turbulent energy [m^2/s^2]
 L : Horizontal wall length [m]
 Nu : Local Nusselt number $\left(Nu = \frac{hL}{k} = \frac{\partial\theta}{\partial X} \Big|_{x=0} \right)$
 \overline{Nu} : Mean Nusselt number $\left(\overline{Nu} = \frac{1}{L} \int Nu \cdot dy \right)$
 Pr : Prandtl number
 T : Temperature [$^\circ\text{C}$]
 T_h : Heating source temperature [$^\circ\text{C}$]
 T_c : Cooled wall temperature [$^\circ\text{C}$]
 ΔT : Temperature difference [$^\circ\text{C}$]
 U : X direction velocity [m/s]
 V : Y direction velocity [m/s]
 β : Thermal expansion coefficient [K^{-1}]

δ_{ij} : Kronecker delta
 ϵ : Turbulent energy dissipation rate
 μ_t : Turbulent eddy viscosity [kg/ms]
 ρ : Density [kg/m^3]

1. Introduction

Natural convection in rectangular enclosures heated on one vertical wall and cooled on the opposite one has received a great deal of attention in recent years. The information concerning buoyancy induced transport in enclosures is very important and effective for the design of electric equipment devices and building (Gebhart et al., 1988). Especially, the heat transfer in rectangular space with a heating source has been applied to industrial problems. These researches are very important to the radiative heat control in PCB (Printed Circuit Board), solar collector, accumulator and ship equipments, and they can change the machinery performances. Thus, there are many kinds of calculation methods for basic or optimum design, and the natural convective heat transfer is very popular to understand the heat transfer mechanism or flow characteristics inducing temperature difference (Jeong et al., 2000;

* Corresponding Author,

E-mail : hschung@gsnu.ac.kr

TEL : +82-55-640-3185; FAX : +82-55-640-3188

School of Mechanical & Aerospace Engineering, Institute of Marine Industry, Gyeongsang National University, Gyeongnam 650-160, Korea. (Manuscript Received April 9, 2003; Revised December 4, 2003)

Lee et al., 1990 ; Kang et al., 1995 ; Suhas, 1980 ; Chung et al., 1999 ; Cheesewright et al., 1986). Many of authors suggested the numerical model to calculate the turbulent natural convection in an enclosure space. Also, it is well known that the low Reynolds number models have a good agreement with experimental results (Kim et al., 1993 ; Seo et al., 1998 ; Kumar 1983). In recently study, standard $k-\varepsilon$ model (Lars 1990) is used commonly for real flow problem at the several fields. But, this model was effective in case of high Reynolds number. Thus, this model was used by coupling with wall functions at the near wall region. But, Chen (Chen et al., 1988) reported that the standard $k-\varepsilon$ model is no suitable at wall and near wall by using wall functions because the turbulence Reynolds number is very small at near wall.

Thus, we conducted some of calculations for selecting the most useful low Reynolds number turbulence model. Figure 1 represents the comparison with Cheesewright's experimental results and three types of low Reynolds number turbulence model, and this contains vertical velocity and turbulent kinetic energy distributions at $Y=1.25$ m and temperature distribution at $X=0.25$ m. In this Fig., ST, LS and DA mean a standard $k-\varepsilon$ turbulence model, low Reynolds number turbulence model by Launder-Sharma and Davison, respectively. In these comparisons, the ST model showed an excessive velocity, temperature and turbulent kinetic energy, and this means the wall boundary condition is very important. The two LS and DA models had a good agreement with

experimental results at whole section. Especially, the LS model was excellent near the wall (Lee et al., 1998 ; Shyy et al., 1993).

In this paper, we perform a numerical simulation of natural convection in a rectangular enclosure for the moving of a heat source by using the LS turbulence model, and the results are compared with the experimental data by holographic interferometer. Also, we suggest the maximum heat transfer point versus heat source positions, and obtain the correlation equations of Nusselt number versus Grashof number.

The final purpose of this study is to obtain the optimum position of a heating source in a rectangular enclosure. And also, the correlation equations with mean Nusselt versus Grashof number were suggested, and these equations can be used to design the heat treatment of building space, warm air circulator and cofferdam tank of LNG (Liquefied Natural Gas) carrier. This carrier ship has a liquefied gas storage tanks which have a very low temperature of -162°C . A general cofferdam tank is located between two LNG tanks, and this cofferdam is used for safety space or repairing equipments. Because this cofferdam tank have to be a thermal environment for comfortable working area, a steam pipe for space heating is installed to preserve a normal temperature.

2. Study Methods

2.1 Numerical simulation

Figure 2 shows the numerical model with $L \times H=0.04 \times 0.12$ (m). We traversed the three type of

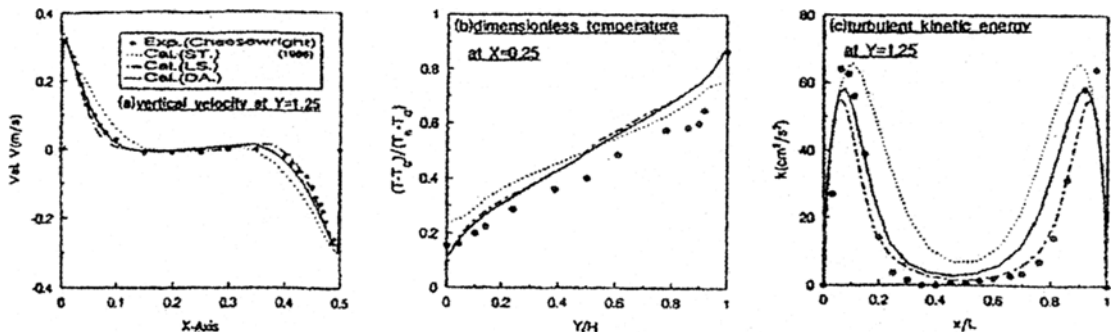

Fig. 1 Comparisons of numerical analysis with several turbulence models and Cheesewright's experimental results (1986) for $L \times H=0.5 \times 2.5$ (m)

the heating source position, $Y=0.03$ m, 0.06 m, and 0.09 m, the top and bottom wall is adiabatic, left and right wall is cooling at constant temperature, $T_c=0^\circ\text{C}$. Also, a heat source is heating at constant temperature, $T_h=20,32$ and 55°C . For numerical simulation we assumed bellows: 1) Steady state. 2) Two dimensional turbulence model. 3) The properties are constant. We introduced the LS model by Launder and Sharma, and the governing equations are given bellow :

Continuity

$$\frac{\partial(\rho U_i)}{\partial X_i} = 0 \tag{1}$$

Momentum

$$\frac{\partial(\rho U_i U_j)}{\partial X_j} = -\frac{\partial P}{\partial X_i} + \frac{\partial}{\partial X_j} \left[\mu \left(\frac{\partial U_i}{\partial X_j} + \frac{\partial U_j}{\partial X_i} \right) \right] - \frac{\partial}{\partial X_j} [\rho \overline{u_i u_j}] + \delta_{ij} \rho g \beta \Delta T \tag{2}$$

Energy

$$\frac{\partial(\rho U_j T)}{\partial X_j} = \frac{\partial}{\partial X_j} \left[\left(\frac{\mu}{Pr} + \mu_t \right) \frac{\partial T}{\partial X_j} \right] \tag{3}$$

Turbulent kinetic energy

$$\frac{\partial(\rho U_j k)}{\partial X_j} = \frac{\partial}{\partial X_j} \left[\left(\frac{\mu_t}{\sigma_k} + \mu \right) \frac{\partial k}{\partial X_j} \right] + G - \rho \epsilon + B - 2\mu \left(\frac{\partial \sqrt{k}}{\partial X_j} \right)^2 \tag{4}$$

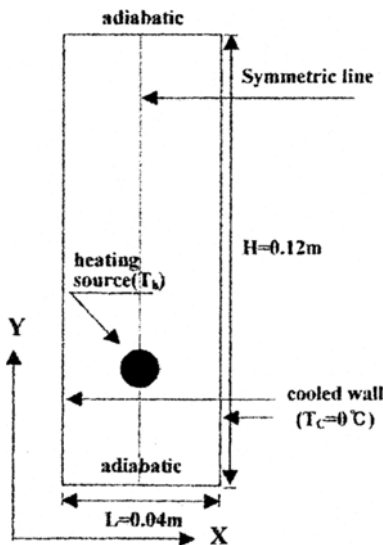

Fig. 2 Schematic diagram for rectangular enclosure with a heating source

Dissipation rate

$$\frac{\partial(\rho U_j \epsilon)}{\partial X_j} = \frac{\partial}{\partial X_j} \left[\left(\frac{\mu_t}{\sigma_\epsilon} + \mu \right) \frac{\partial \epsilon}{\partial X_j} \right] + C_{1\epsilon} \frac{\epsilon}{k} (G+B) - C_{2\epsilon} f_2 \frac{\rho \epsilon^2}{k} + 2 \frac{\mu \mu_t}{\rho} \left(\frac{\partial^2 U_t}{\partial X_j \partial X_k} \right) \tag{5}$$

where G and B are the turbulent generation term and the buoyancy term, respectively :

$$G = \mu_t \left(\frac{\partial U_i}{\partial X_j} + \frac{\partial U_j}{\partial X_i} \right) \frac{\partial U_i}{\partial X_j} \tag{6}$$

$$B = -g \beta \frac{\mu_t}{\sigma_t} \frac{\partial T}{\partial y}$$

Here, the turbulence model constants and functions are given as follows :

$$C_{1\epsilon}=1.44, C_{2\epsilon}=1.92, \sigma_\epsilon=1.3, \sigma_k=1.0, C_\mu=0.09, \sigma_t=0.9$$

$$f_2 = 1 - 0.3 \exp(-R_{et}^2), f_\mu = \exp \left\{ \frac{-3.4}{(1 + R_{et}/50)^2} \right\} \tag{7}$$

$$R_{et} = \frac{\rho k^2}{\mu \epsilon}, \mu_t = \frac{f_\mu C_\mu \rho k^2}{\epsilon}$$

In this study, we adopted a finite volume method for solving each values from given equations, SIMPLE algorithm and hybrid scheme were used to solve a pressure and a convection term.

Figure 3 shows a grid system for numerical

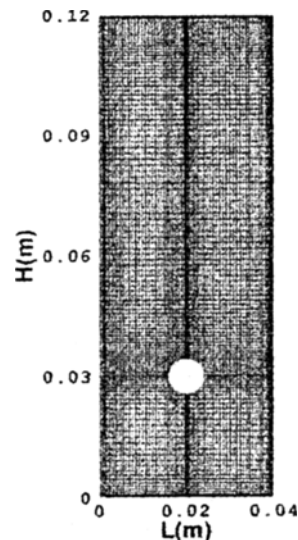

Fig. 3 Grid generation system

analysis, and adopted a non-constant grid by using Eq. (8) for dense arrangement near a heat

source and the wall side.

$$X_i = X_{\max} \left[-0.5 \tanh \left\{ a \left(2 \frac{i}{n-1} \right) / \tanh(-a) + 0.5 \right\} \right] \quad (8)$$

where n is the grid number of X-direction. The i is a coordinate position and a is a coefficient for adjusting grid interval. The diameter of a heating source is 0.008 m.

2.2 Experimental methods

Figure 4 shows the experimental apparatus. The experimental test section is rectangular enclosure with $0.04 \times 0.12 \times 0.4$ (m). The heating source is used a sheath heater that the diameter is 8mm and traversed to vertical direction at symmetric line of rectangular space. The left and right walls are adjacent to cooling chambers with 0°C temperatures, it is preserved by mixing a ice, salt and water. The temperature measurement was conducted by using T-type thermocouple, hybrid recorder and P/C, and a holographic interferometer was used for visualization as shown in Fig. 5 and Fig. 6. A light source of the holographic interferometer was He-Ne laser with $\lambda = 662.8 \mu\text{m}$, and used the general steal camera with a 105 mm lens and filter type of ND4, ND2. The low sensitivity film (ASA 25) was used and the time of exposure was 10~11 sec.

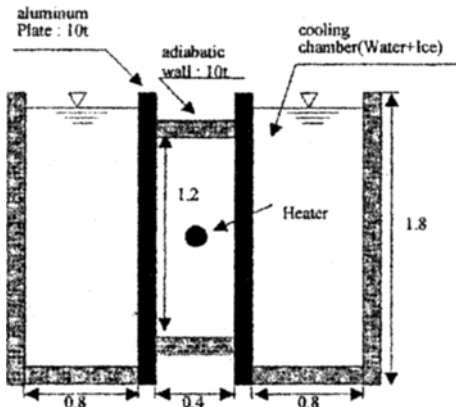

Fig. 4 Experimental apparatus of rectangular enclosure with a heating source

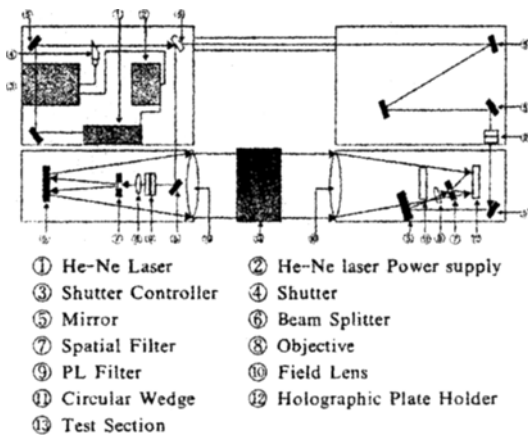

Fig. 5 Schematic diagram of holographic interferometer



Fig. 6 The photographic of holographic interferometer

3. Results & Discussion

Figures 7~8 show comparisons with experimental and numerical isotherms according to the position of a heating source and the various ΔT .

Figure 7 represents the experimental photograph and the numerical result when the a heating source is on the lower position for various temperature differences (20, 32 and 47°C). Because the air is expanded to the upper space by heating, the density of isotherms was great around the heating source, and these were more dense at the upper space than the lower space. The gradient of isotherm line with the surface of heating source and the wall side is very important because of it has different the gradient according to the temperature variations. It is mean that the heat

transfer is come active. Therefore, the heat transfer is more large in accordance with the gradient is more small when the position of a heating source is lower.

Figure 8 shows results for the center position, and the temperature distributions were very similar to the above case, but it was more dense near the ceiling. In this results, the gradient of isotherms line is showed the reverse pattern above results and the gradient is more large as ΔT is increasing. Because the space between heating source and upper wall is small than the heating source is lower position.

Figure 9 shows velocity vectors for various ΔT at the lower position of a heating source. The velocity vectors were very large at the center and side wall ; one is up-flow by the buoyancy of hot fluid and the other is down-flow by side cooling walls. As temperature differences are increased, the magnitudes of velocity vectors were very small at the lower space of a heating source.

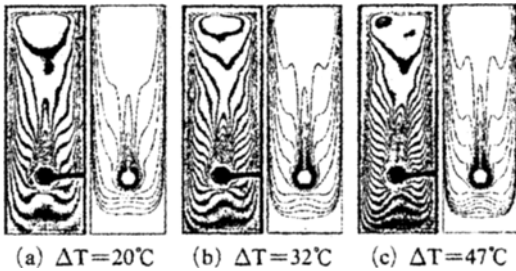

Fig. 7 Comparison with experimental and numerical isotherms for various ΔT (lower position)

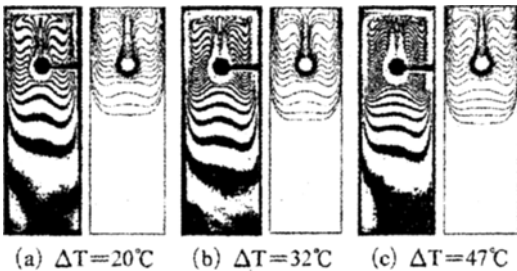

Fig. 8 Comparison with experimental and numerical isotherms for various ΔT (upper position)

The velocity vectors on various ΔT at upper position appear in Figure 10. The vectors were appeared very small at lower space under a heating source like to results in Figure 9.

Figure 11 represents the velocity distributions for U-direction along Y/H at $X=0.025$ m. As a heating source was moved for upper space, the velocity is nearly zero at lower space of a heating source. Because the heated air is raised to upper direction.

Figure 12 shows the velocity of V-direction along X/L at $Y=0.3$ and 0.9 m. The velocity is showed the distribution of the positive and negative part with a heating source. Also, the velocity distributions are appeared the positive distribution at near of a heating source. As a heating

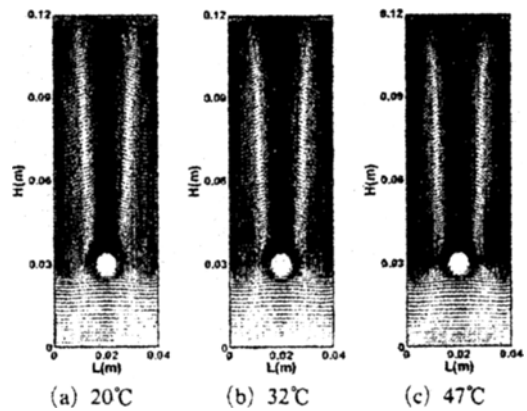

Fig. 9 Velocity vector on various ΔT at lower position

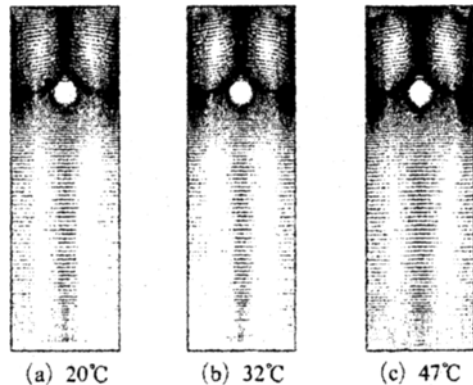

Fig. 10 Velocity vector on various ΔT at upper position

source is moving to upper space in a rectangular enclosure, the velocity distributions are more large with ΔT .

Figure 13 represents the Nusselt number distribution on side of the vertical wall along the position of a heating source. The Nusselt number was very small at the lower wall and large at the upper wall from the heating source. The gradient of the Nusselt number was zero at $Y/H \approx 0.9$, this means that there is a stagnation region at near the ceiling.

Figure 14 represents a distribution of vertical wall's mean Nusselt number versus Grashof number for various positions of a heating source. The

mean Nusselt number is increased proportionally to the Grashof number, the heat transfer at $Y/H=0.5$ was greater about 13% than other cases. Also, the relationships between the mean Nusselt number and Grashof number on each position could be obtained, and the correlation equations are as follows :

at lower position

$$\overline{Nu} = 1.44 + 1.13 \times 10^{-7} Gr - 2.35 \times 10^{-15} Gr^2$$

$$(4.0 \times 10^6 \leq Gr \leq 1.8 \times 10^8)$$

at center position

$$\overline{Nu} = 0.65 + 2.94 \times 10^{-7} Gr - 8.80 \times 10^{-15} Gr^2$$

$$(4.0 \times 10^6 \leq Gr \leq 1.8 \times 10^8)$$

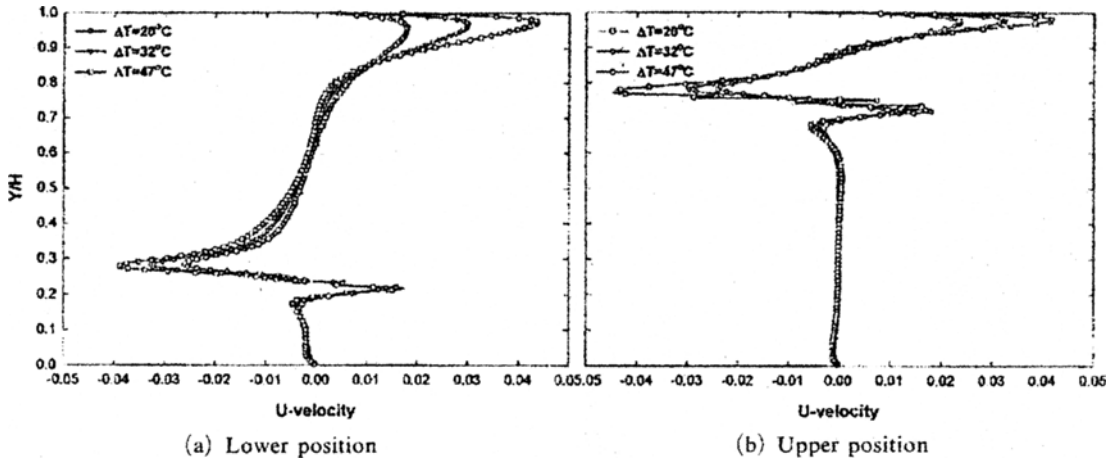

Fig. 11 U Velocity distributions along Y/H at X=0.025 m

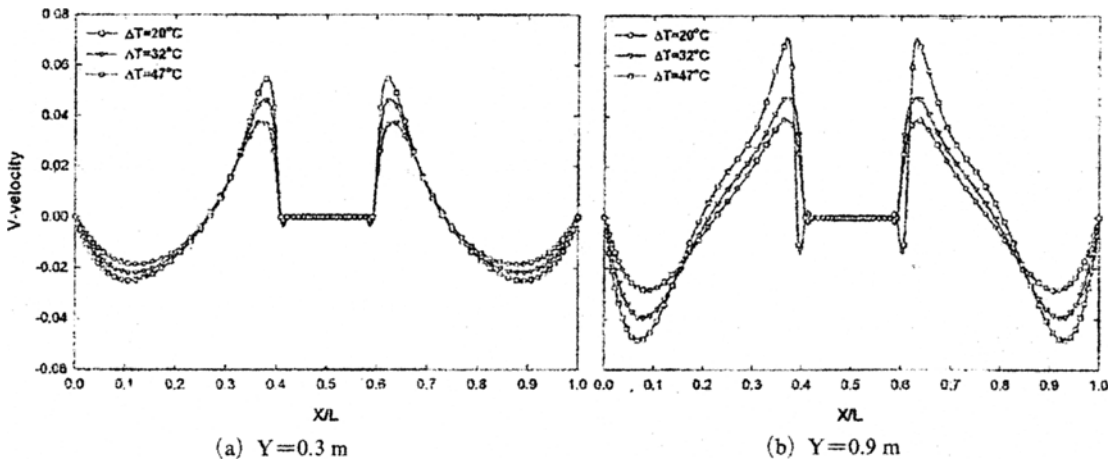

Fig. 12 V Velocity distributions along X/L at Y=0.3 and 0.9 m

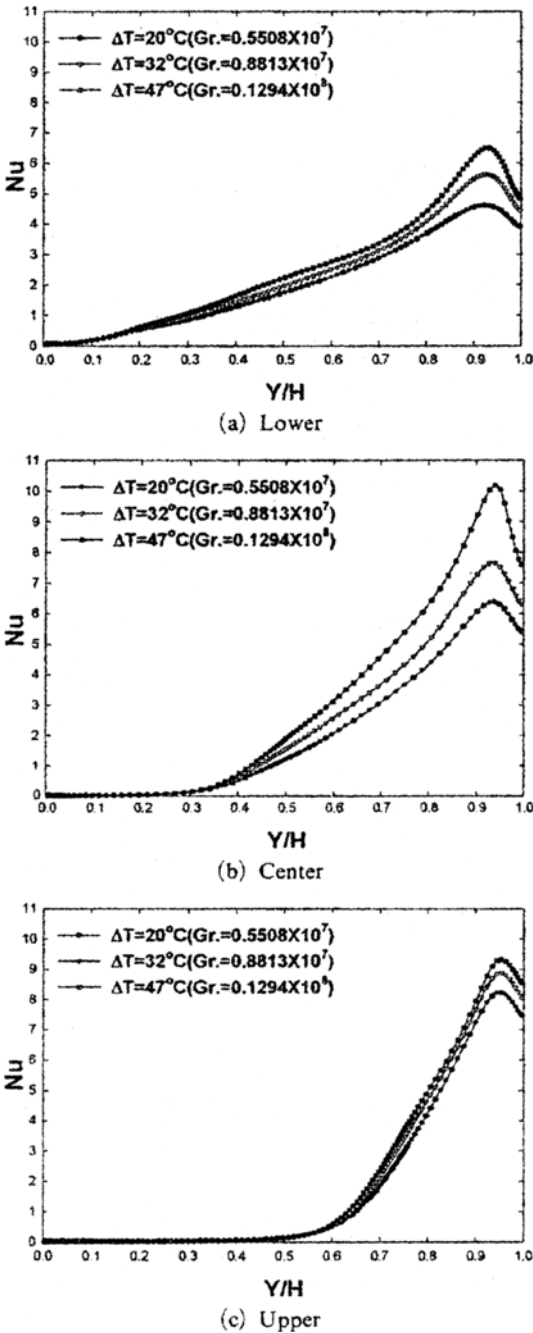

Fig. 13 Nusselt number distributions on vertical wall for various heating positions by numerical analysis

at upper position

$$\overline{Nu} = 1.55 + 5.72 \times 10^{-8} Gr - 1.13 \times 10^{-15} Gr^2 \quad (9)$$

$(4.0 \times 10^6 \leq Gr \leq 1.8 \times 10^8)$

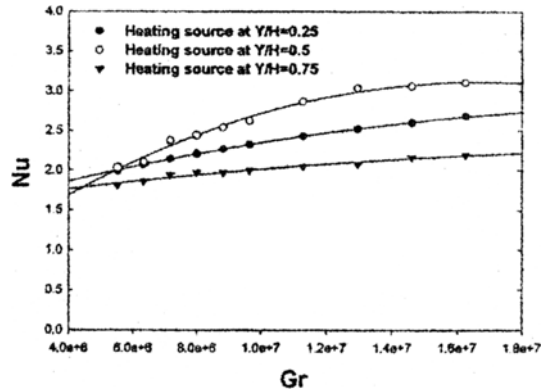

Fig. 14 Distributions of Nusselt number vs. Grashof number with each position by numerical analysis

3. Conclusions

The numerical analysis and experimental research of natural convection in a rectangular enclosure was carried out for the moving of heating source, the main results are summarized as the followings.

(1) The isotherm distributions of numerical analysis and experimentation show the qualitatively same results and as the temperature increases, the dense isotherm is appeared around the heating source.

(2) The gradient of isotherms line is very important to valuation of heat transfer, the heat transfer is increased according to the gradient is more small at lower position. But, the heat transfer is increased in accordance with the gradient is more large at upper position.

(3) The lower space of a heating source had very small velocity vectors, and temperature was very low, thus, as increasing the temperature differences, the isotherms were dense at the center and wall.

(4) The local Nusselt number on the side wall was increased according to the vertical wall because of the heated fluid is uprising by effect of buoyancy, but the gradient of Nusselt number was zero at $Y/H \approx 0.9$ because of the fluid at upper corner was occurred the stagnation by swirl flow.

(5) The relation equations between the mean

Nusselt number and Grashof number were obtained, and the maximum value of heat transfer was obtained to 3.1 in case that the heating source was located at center position. Therefore, the heat transfer at center position was rated about 13% more than other cases.

Acknowledgment

This work was supported by the Brain Korea 21 Projects, and the authors gratefully appreciate the support.

References

- Cheesewright, R., King, K. J. and Ziai S., 1986, "Experimental Data of the Validation of Computer Codes for the Prediction of Two Dimensional Buoyancy Cavity Flow," *Significant Questions in Buoyancy Affected Enclosure or Cavity Flows, ASME-HTD*, pp. 75~81.
- Chen, Q., van der kooi, J. and Meyers, A., 1988, "Measurement and Computations of Ventilation Efficiency and Temperature Efficiency in a Ventilated Room," *Energy and Buildings*, Vol. 12, pp. 85~99.
- Chung, H. S., Jeong, H. M., Kim, K. K. and Ro, S. T., 1999, "The Turbulent Natural Convection in Membrane Type LNG Carrier Cofferdam," *Trans. of KSME*, Part B, Vol. 23, No. 2, pp. 281~287.
- Gebhart, B., Jaluria, Y., Mahajan, R. L. and Sammakia, B., 1988, "Buoyancy-Induced Flows and Transport," *Hemisphere Pub. CO*.
- Jeong, H. M., Lee, C. J. and Chung, H. S., 2000, "Study on the Numerical Modeling of Turbulent Natural Convection in Rectangular Enclosure," *Trans. of SAREK*, Vol. 10, No. 2, pp. 33~39.
- Kang, D. K., Kim, W. S. and Lee, K. S., 1995, "A Numerical Study on the Two-Dimensional Turbulent Natural Convection Using a Low-Reynolds Number $k-\epsilon$ Model," *Trans. of KSME*, Vol. 19 No. 3, pp. 741~750.
- Kim, T. G. and Sung, H. J., 1993, "A Hybrid Turbulence Model for Prediction of Buoyancy-Driven Turbulent Thermal Convection Flow," *Trans. of KSME*, Vol. 17, No. 8, pp. 2069~2078.
- Kumar, K., 1983, "Mathematical Modeling of Natural Convection in Fire—a State of the Art Review of the Field Modeling of Variable Density Turbulent Flow," *Fire and Materials*, Vol. 103, pp. 456~460.
- Lars Davidson, 1990, "Calculation of the Turbulent Buoyancy-Driven Flow in a Rectangular Cavity using an Efficient Solver and Two Different Low Reynolds number $k-\epsilon$ Turbulence Models," *Numerical Heat Transfer, Part A*, Vol. 18, pp. 129~147.
- Lee, C. J., Jeong, H. M., Chung, H. S. and Kim, K. K., 1998, "Study on the Natural Convection of Rectangular Enclosure with Heating Source," *Proceeding of KSME*, Part B, pp. 417~421.
- Lee, J. H., Kim, M. H. and Moh, J. H., 1990, "Natural Convection Heat Transfer in Rectangular Air Enclosure with Adiabatic and Isothermal Horizontal Boundary Condition," *Trans. of KSME*, Vol. 14, No. 1, pp. 207~213.
- Seo, H. T., Lee, D. S., Yoon, S. H. and Boo, J. S., 1998, "Numerical Analysis on Wall-Attaching Offset Jet with Various Turbulent $k-\epsilon$ Models and Upwind Scheme," *Trans. of KSME*, Part B, pp. 828~835.
- Shyy, W. and Rao, M. M., 1993, "Simulation of Transient Natural Convection Around an Enclosed Vertical Channel," *Journal of Heat Transfer, ASME*, Vol. 115, pp. 946~954.
- Suhas, V. Patankar, 1980, *Numerical Heat Transfer and Fluid Flow*, McGrawhill Co.